

DATA SHEET

Frequency converter FU IP 20 230V

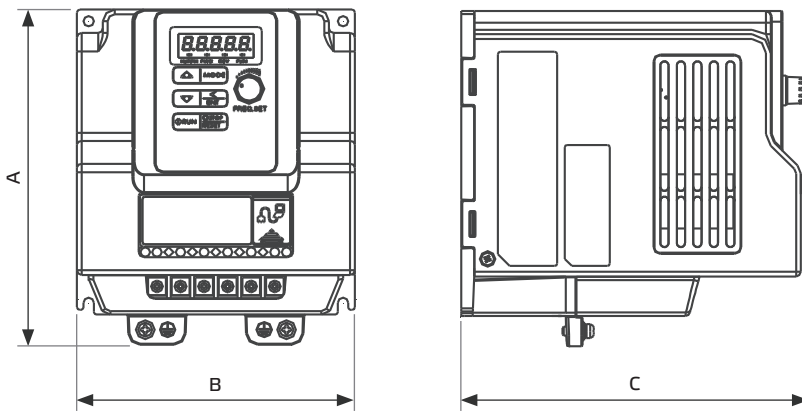

Type	ID	A mm	B mm	C mm	D mm	E mm	Weight kg
FU 075 08	141836	141	72	141	122	61	1,0
FU 075 09	141837	141	72	141	122	61	1,0
FU 075 10	141838	141	72	141	122	61	1,0
FU 075 11	141840	141	72	141	122	61	1,0
FU 075 12	141841	141	72	141	122	61	1,0
FU 075 13	141842	141	72	141	122	61	1,0
FU 15 08	141839	144	118	150	121	108	1,5
FU 15 09	141843	144	118	150	121	108	1,5
FU 15 10	141844	144	118	150	121	108	1,5
FU 22 10	141845	144	118	150	121	108	1,5

- Frequency converter
- Supply voltage 230 V 1~ 50/60 Hz
- Output voltage 0 - 230 V 3~
- Variable speed control
- Motor-/converter protection
- Integrated interference filter/class A
- Integrated Modbus or BacNet interface
- Configurable status/fault relay
- Easy start-up
- Temperature range -10 °C ... +40 °C
- Protection Class IP 20

Type	ID	P ₂ kW	I _A A	For models:
FU 075 08	141836	0,75	4,3	MPS 225 D2 30, MPC 225 D2 30/T30
FU 075 09	141837	0,75	4,3	MPS 250 D2 30, MPC 250 D2 30/T30
FU 075 10	141838	0,75	4,3	MPS 280 D2 30, MPC 280 D2 30/T30
FU 075 11	141840	0,75	4,3	MPS 315 D4 30, MPC 315 D4 30/T30
FU 075 12	141841	0,75	4,3	MPS 355 D4 30, MPC 355 D4 30/T30
FU 075 13	141842	0,75	4,3	MPS 400 D4 30, MPC 400 D4 30/T30
FU 15 08	141839	1,5	7,5	MPS 315 D2 30, MPC 315 D2 30/T30
FU 15 09	141843	1,5	7,5	MPS 450 D4 30, MPC 450 D4 30/T30
FU 15 10	141844	1,5	7,5	MPS 500 D4 30, MPC 500 D4 30/T30
FU 22 10	141845	2,2	10,5	MPS 560 D4 30, MPC 560 D4 30/T30

Wiring diagram :

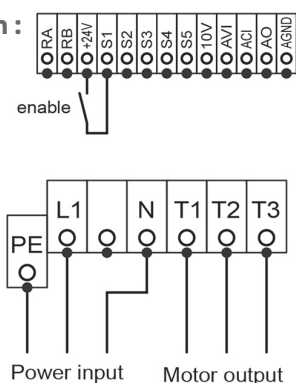

Assembly :

