

Type DHA 315 E4 42
ID 156469

Aansluitgegevens van het complete apparaat

Nominale frequentie	Hz	50
Nominale spanning	V	230
Nominaal opgenomen vermogen	W	113
Max. bedrijfsstroom	A	0.6
Fasen		1~
Motortype		1~
Besturingstype motor		V
Motorbeveiliging		TAI
Condensatorcapaciteit	µF	4
Condensatorspanning	V	400
Isolatieklasse motor		B
Aantal polen		4
IP-beschermingsklasse motor		IP44
IP-beschermingsklasse klemmenkast		-
IP beschermingsgr. compl. app.		-
Min. werktemperatuur	°C	-25

Nominale stroom	A	0.5
Nominaal toerental	1/min	1380
Max. stat. rendement	%	38.1
Max. tot. rendement	%	40.7
Max. toelaatbare frequentie (bij 3~ motoren)	Hz	-
Max. toelaatbaar toerental (bij EC-motoren)	1/min	-
Max. opgenomen vermogen	W	113
Max. opgenomen stroom	A	0.6
Max. toerental	1/min	1425
Max. luchtvolume	m³/h	1970
Min. druk	Pa	-
Max. druk	Pa	230
Max. toelaatbare omgevingstemperatuur bij nominale stroom	°C	60
Max. toelaatbare mediumtemperatuur bij nominale stroom	°C	60
Max. toelaatbare omgevingstemperatuur	°C	60
Max. toelaatbare mediumtemperatuur	°C	60
Sperstroom	A	-
Min. toelaatbare spanning	V	80
Gewicht	kg	8,5

Geluidsmeting (octaven)

Geluidsmeting (octaven)			Σ	63 Hz	125 Hz	250 Hz	500 Hz	1k Hz	2k Hz	4k Hz	8k Hz	
Geluidsvolume inlaat	L _{WA5}	dB(A)	1	64	48	55	56	59	58	56	49	39
			2	63	45	53	53	58	56	57	48	35
			3	64	41	51	52	57	57	60	51	36
			4	65	40	52	52	57	56	62	59	39
			5	69	38	58	53	59	59	65	65	47
Geluidsvolume uitblaas	L _{WA6}	dB(A)	1	70	48	55	59	63	66	63	56	47
			2	68	47	55	58	62	63	62	53	42
			3	67	41	52	55	59	62	63	53	39
			4	69	40	54	56	59	62	65	62	42
			5	73	38	57	57	61	64	69	68	49
Geluidsvolume door afgifte	L _{WA2}	dB(A)	1	-	-	-	-	-	-	-	-	-
			2	-	-	-	-	-	-	-	-	-
			3	-	-	-	-	-	-	-	-	-
			4	-	-	-	-	-	-	-	-	-
			5	-	-	-	-	-	-	-	-	-

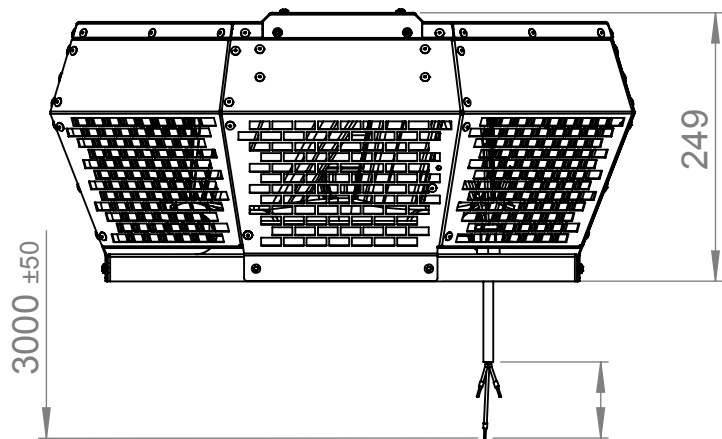

100 ±5

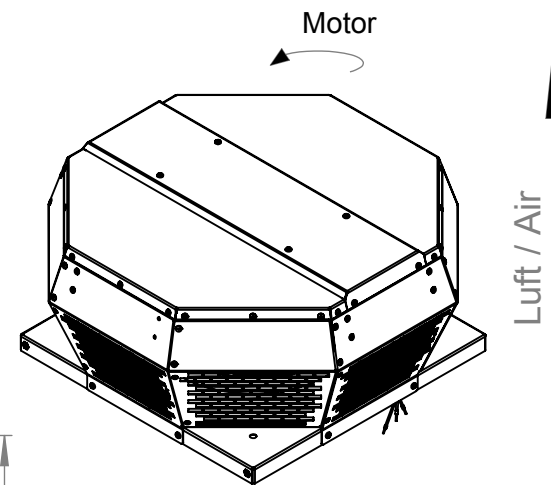
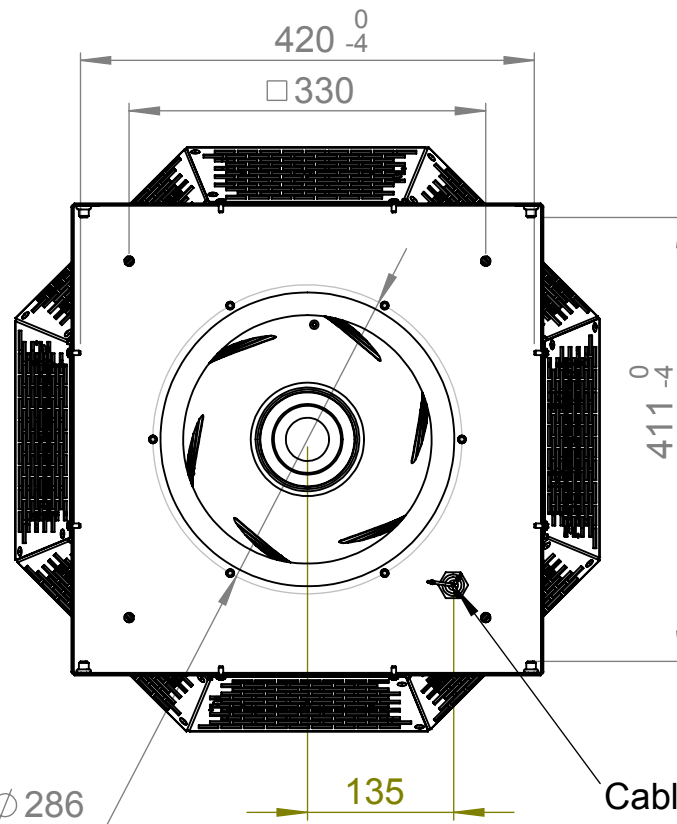
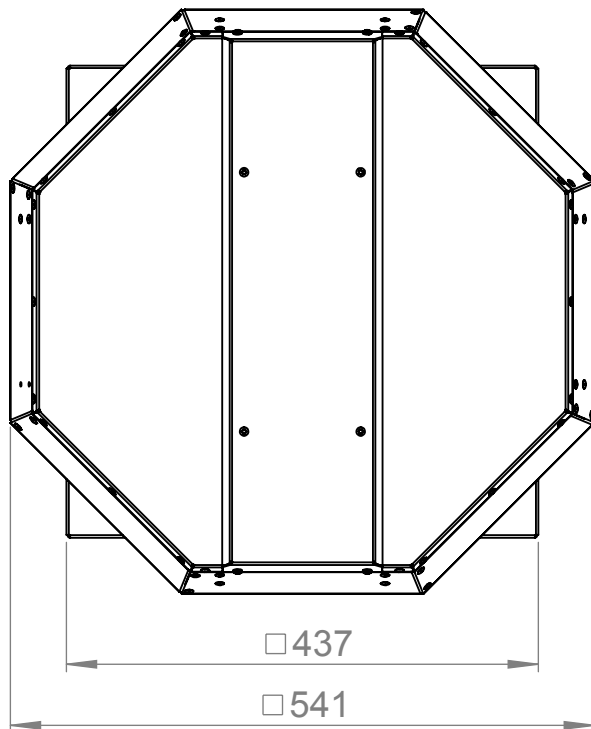

Protection Mark
according to ISO 16016

Created d.hancu
Drawn d.hancu
Released
Disabled

1:7 A4 mm

General tolerances
DIN ISO 2768-c

04.12.2020
04.12.2020

DHA315E442

156469 00